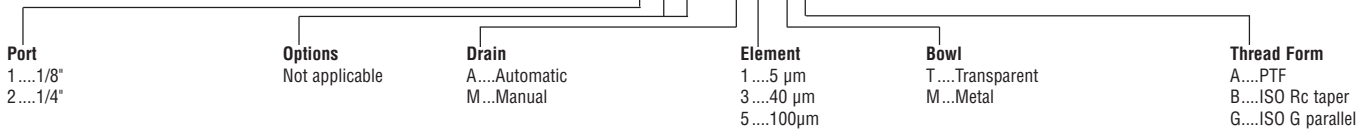

**General Purpose Filter  
F07 - ★★ - ★★**

**TECHNICAL DATA**

Fluid: Compressed air  
 Maximum pressure:  
 Transparent bowl: 10 bar (150 psig)  
 Metal bowl: 17 bar (250 psig)  
 Operating temperature\*:  
 Transparent bowl: -34° to +50°C (-30° to +125°F)  
 Metal bowl: -34° to +80°C (-30° to +175°F)  
 \* Air supply must be dry enough to avoid ice formation at temperatures below +2°C (+35°F).  
 Particle removal: 5 µm, 40 µm, or 100 µm filter element  
 Air quality: Within ISO 8573-1, Class 3 and Class 5 (particulates)  
 Typical flow with a 5µm element at 6,3 bar (90 psig) inlet pressure and 0,35 bar (5 psig) pressure drop:  
 1/8" Ports: 9 dm<sup>3</sup>/s (19 scfm)  
 1/4" Ports: 11.5 dm<sup>3</sup>/s (24 scfm)  
 Drain connection: 1/8" pipe thread  
 Automatic drain operation: Spitter type drain operates momentarily when a rapid change in air flow occurs or when supply pressure is reduced.  
 Nominal bowl size: 31 ml (1 fluid ounce)  
 Materials:  
 Body: Zinc  
 Bowl:  
 Transparent: Polycarbonate  
 Metal: Zinc  
 Element: Sintered polypropylene  
 Elastomers: Neoprene and nitrile

**REPLACEMENT ITEMS**

Service Kits (includes items circled on exploded view):  
 5µm filter element .....3652-11  
 25µm filter element .....3652-10  
 40µm filter element .....3652-09  
 Manual drain (20, 26) .....773-03  
 Auto drain (21, 22) (27, 28).....3654-02

**INSTALLATION**

- Shut-off air pressure. Install filter in air line -
  - vertically (bowl down),
  - with air flow in direction of arrow on body,
  - upstream of regulators, lubricators, and cycling valves,
  - as close as possible to the air supply when used as a main line filter,
  - as close as possible to the device being serviced when used as a final filter.
- Connect piping to proper ports using pipe thread sealant on male threads only. Do not allow sealant to enter interior of unit.
- On filters equipped with an automatic drain, slip 1/4" I.D. flexible tube over protrusion on bottom of bowl. Avoid restrictions in the tube. Bowl protrusion is also threaded to accept 1/8" pipe thread fitting.
- Turn bowl fully clockwise into body before pressurizing.

**SERVICING**

- Depress manual drain to expel accumulated liquids. Keep liquids below element (31, 34).
- Clean or replace filter element when dirty.

**DISASSEMBLY**

- Filter can be disassembled without removal from air line.
- Shut off inlet pressure. Reduce pressure in inlet and outlet lines to zero.
- Turn bowl counterclockwise and remove from body.
- Disassemble in general accordance with the item numbers on exploded view. Do not remove the manual drain unless replacement is necessary. Remove and replace only if it malfunctions.

**CLEANING**

- Clean plastic bowl with warm water only. Clean other parts with warm water and soap.
- Rinse and dry parts. Blow out internal passages in body (1, 1A) with clean, dry compressed air. Blow air through filter element (31, 34) from inside to outside to remove surface contaminants.
- Inspect parts. Replace those found to be damaged. Replace plastic bowl with a metal bowl if plastic bowl shows signs of cracking or cloudiness.

**ASSEMBLY**

- Lubricate seals and o-rings with o-ring grease. Apply a small amount of anti-seize lubricant to full length of threads on metal bowls.
  - Assemble filter as shown on the exploded view.
- | 31 (Element)                | Torque in N-m (Inch Pounds) |
|-----------------------------|-----------------------------|
| 32 (Stud)                   | 0,56 to 1,13 (5 to 10)      |
| 23, 29 (Bowl)               | 0,56 to 1,13 (5 to 10)      |
| 20, 26 (Manual drain valve) | 0,17 to 0,28 (1.5 to 2.5)   |

**CAUTION**

Water vapor will pass through these units and could condense into liquid form downstream as air temperature drops. Install an air dryer if water condensation could have a detrimental effect on the application.

**WARNING**

These products are intended for use in industrial compressed air systems only. Do not use these products where pressures and temperatures can exceed those listed under **Technical Data**.

Polycarbonate plastic bowls can be damaged and possibly burst if exposed to such substances as certain solvents, strong alkalis, compressor oils containing ester-based additives or synthetic oils. Fumes of these substances in contact with the polycarbonate bowl, externally or internally, can also result in damage. Clean with warm water only.

Use metal bowl in applications where a plastic bowl might be exposed to substances that are incompatible with polycarbonate.

Before using these products with fluids other than air, for nonindustrial applications, or for life-support systems consult Norgren.

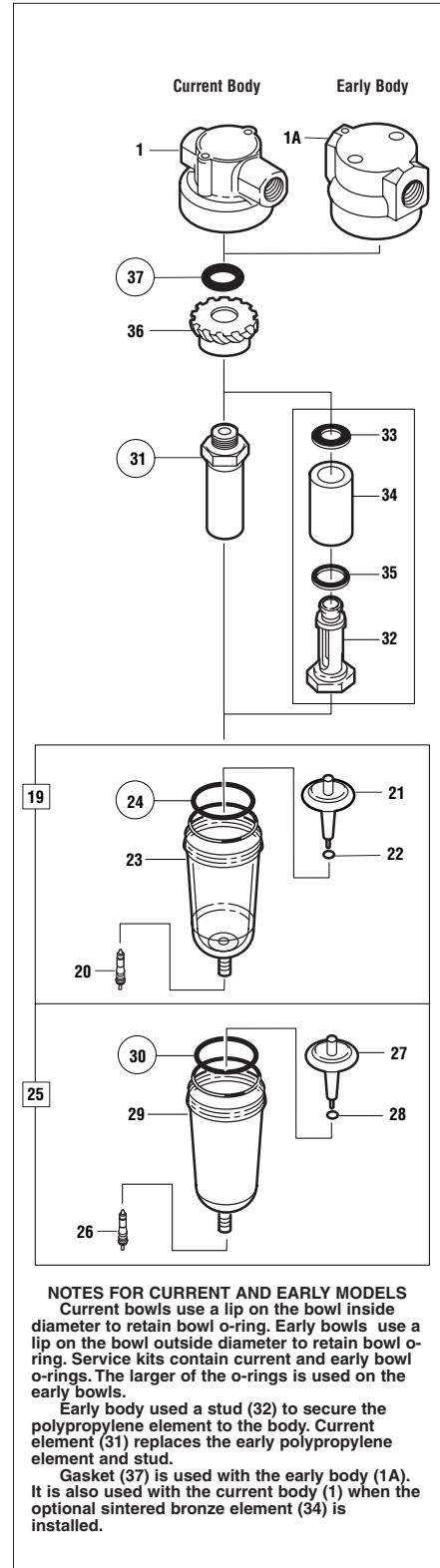
**NOTES FOR CURRENT AND EARLY MODELS**

Current bowls use a lip on the bowl inside diameter to retain bowl o-ring. Early bowls use a lip on the bowl outside diameter to retain bowl o-ring. Service kits contain current and early bowl o-rings. The larger of the o-rings is used on the early bowls.

Early body used a stud (32) to secure the polypropylene element to the body. Current element (31) replaces the early polypropylene element and stud.

Gasket (37) is used with the early body (1A). It is also used with the current body (1) when the optional sintered bronze element (34) is installed.